

EC800X QuecDuino EVB

EC800X QuecDuino EVB

V1.1

2024-12-25

LX



1

EC800X QuecDuino EVB EC800
EC800M EC800K EG800K EC800E

1.1 EC800X QuecDuino EVB

QuecDuino EVB 4G FPC

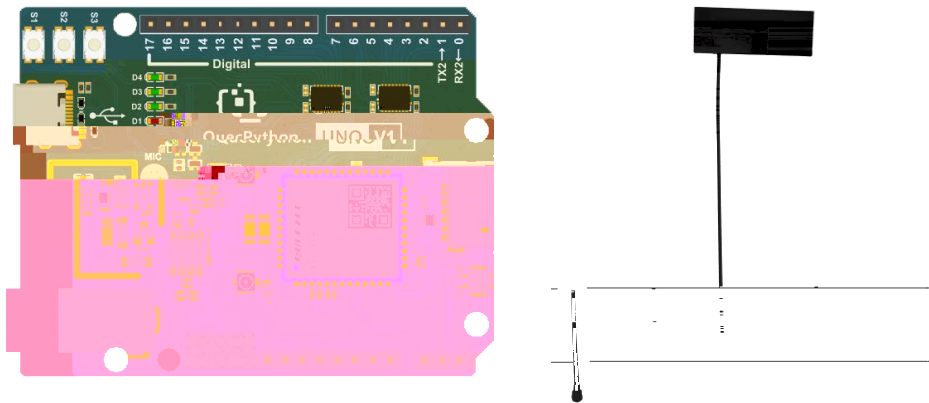

1 EVB

Features

CPU

EC800 / EG800 Module Series

Pins

22x digital pins (GPIO), D0-D3,0-17 up to
2x analog input pins (ADC), A0-A1

Peripherals

Antenna Interface,LTE & GNSS(option)

SIM Interface, NANO SIM

USB 2.0, TypeC

Arduino female header Interface

Audio(option)

1xMIC onboard

1x 3W Class-D Stereo Amplifier

Power

Recommended input voltage (VIN) is 4.5-5.25 V/2A

Power via USB-C® at 5 V

Power via DC05® at 5-16V

3.3V/200mA output

Communication

4x UART (pin 0, 7) up to

1x SPI (pin 10-13, ICSP header)

1x I2C (pin 16, 17, SDA, SCL)

3x KEY(S1-S3)

4x LED(D1-D4)

1x RESET(Pull-down reset Module)

1x BOOT(According to different model modules pull up or Pull-down the BOOT pin, Before power-on)

2

2.1

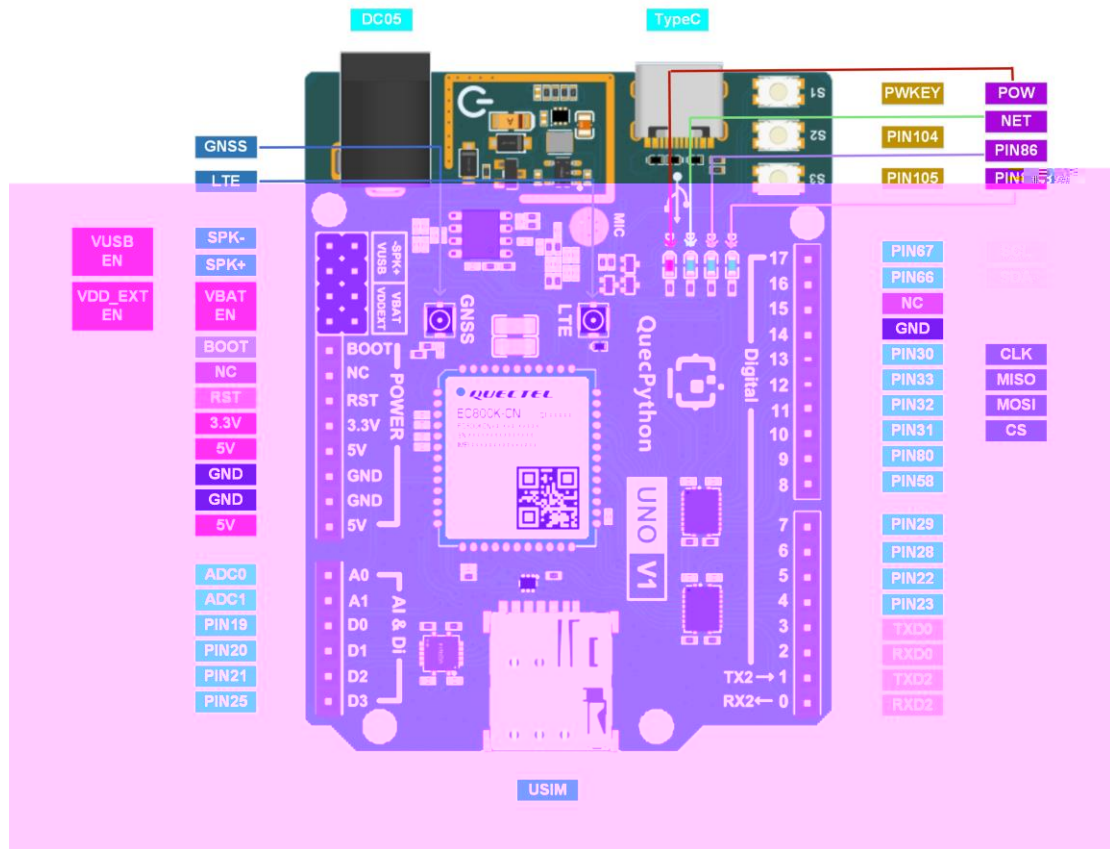

2 EVB

EVB

VUBS EN VDD_EXT EN VBAT EN

2.2

1

		DC
BOOT	USB_BOOT	
NC		
RST	RESET	

3.3V		3.3V/200mA
5V	/	5V/2A V1.1
GND		
GND		
5V	/	5V/2A V1.1
A0	ADC0	0-1.2 V
A1	ADC1	0-1.2 V
D0	I/O 19	3.3V
D1	I/O 20	3.3V
D2	I/O 21	3.3V
D3	I/O 25	3.3V
0		3.3V
1		3.3V
2		3.3V
3		3.3V
4	I/O 23	3.3V
5	I/O 22	3.3V
6	I/O 28	3.3V
7	I/O 29	3.3V
8	I/O 58	3.3V
9	I/O 80	3.3V
10	I/O 31	3.3V
11	I/O 32	3.3V
12	I/O 33	3.3V
13	I/O 30	3.3V
14		
15	NC	
16	I/O 66	3.3V

BOOT
BOOT

BOOT

BOOT GND

2.3

EVB 4

D1

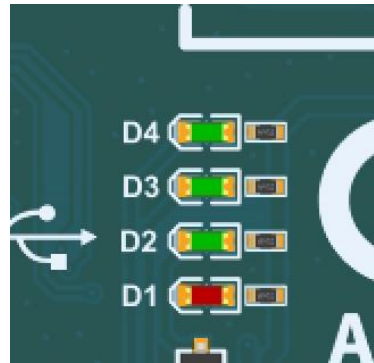

5

D2

2

D2	200ms /1800ms	
	1800ms /200ms	
	125ms /125ms	

D3 D4

86 87

3 SIM



6 SIM

EVB NANO SIM USIM ETSI IMT-2000
1.8 V 3.0 V USIM

4 USB

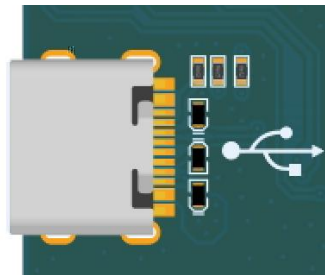

7 USB

EVB 1 TypeC USB USB USB 2.0
USB 2.0 AT 480 Mbps GNSS NMEA 12 Mbps

5 ADC

EVB 2

ADC

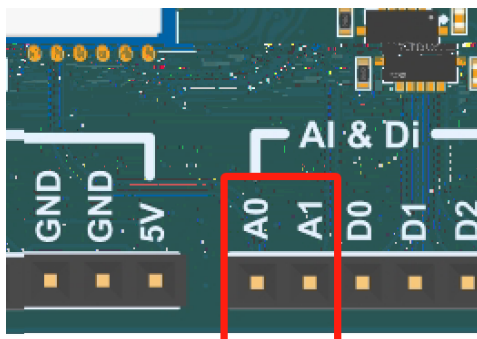

8 ADC

3 ADC

参数	最小值	典型值	最大值	单位
ADC0 电压	0	-	1.2	V
ADC1 电压	0	-	1.2	V
ADC 分辨率	-	-	12	位

6

6.1

6.1.1

5

引脚名	引脚号	I/O	描述	备注
ANT_MAIN	35	AIO	主天线接口	50 Ω 特性阻抗。

备注

模块支持 Wi-Fi Scan 功能。由于共用主天线接口，两种功能不可同时使用，时分复用，Wi-Fi Scan 只接收不发送。

6

工作频段	发送 (MHz)	接收 (MHz)	接收
~2170	LTE-FDD B1	1920~1980	2110~
~1880	LTE-FDD B3	1710~1785	1805~
934	LTE-FDD B5	824~849	869~
960	LTE-FDD B8	880~915	925~
~2025	LTE-TDD B34	2010~2025	2010~
~2620	LTE-TDD B38	2570~2620	2570~
~1920	LTE-TDD B39	1880~1920	1880~
~2400	LTE-TDD B40	2300~2400	2300~
~2675	LTE-TDD B41	2535~2675	2535~

6.1.2

7

频段	最大值	最小值
LTE-FDD B1/B3/B5/B8	23 dBm \pm 2 dB	< -39 dBm
LTE-TDD B34/B38/B39/B40/B41	23 dBm \pm 2 dB	< -39 dBm

6.1.3

8

频段	接收灵敏度 (典型值) (dBm)			3GPP 要求 (主集 + 分集)
	主集	分集	主集 + 分集	
LTE-FDD B1 (10 MHz)	-99.5 dBm	-	-	-96.3 dBm
LTE-FDD B3 (10 MHz)	-99.0 dBm	-	-	-93.3 dBm
LTE-FDD B5 (10 MHz)	-98.5 dBm	-	-	-94.3 dBm
LTE-FDD B8 (10 MHz)	-99.0 dBm	-	-	-93.3 dBm
LTE-TDD B34 (10 MHz)	-100.0 dBm	-	-	-96.3 dBm
LTE-TDD B38 (10 MHz)	-99.0 dBm	-	-	-96.3 dBm
LTE-TDD B39 (10 MHz)	-100.0 dBm	-	-	-96.3 dBm
LTE-TDD B40 (10 MHz)	-100.5 dBm	-	-	-96.3 dBm
LTE-TDD B41 (10 MHz)	-99.0 dBm	-	-	-94.3 dBm

6.2 GNSS

- EVB GNSS GNSS
- GPS BDS GLONASS Galileo
- NMEA 0183 NMEA AT USB
- UART 1 Hz
- GNSS AT

6.2.1

9

GPS	1575.42 ±1.023 (L1)	MHz
BDS	1561.098 ±2.046 (B1I)	
Galileo	1575.42 ±2.046 (E1)	
GLONASS	1597.5~1605.8 (L1)	

6.2.2 GNSS

10 GNSS

参数	条件	典型值	单位
灵敏度	捕获	-146	dBm
	重捕	-160	
	追踪	-160	
首次定位时间	冷启动 @ 空旷区域	28	s
	温启动 @ 空旷区域	27	
	热启动 @ 空旷区域	3.7-3.8	
定位精度	CEP-50	2	m

备注

1. 追踪灵敏度：模块可以保持对导航信号的跟踪和定位所需的最低信号电平（连续定位至少3分钟）。
2. 重捕灵敏度：模块接收的导航信号失锁后3分钟内，重新捕获导航信号并正常定位所需的最低信号电平。
3. 捕获灵敏度：模块接收冷启动后3分钟内，捕获导航信号并成功定位所需的最低信号电平。

11

mm

IPEX

<https://www.i-pex.com>

7

7.1

11

TypeC	-0.3	6	V
DC	-0.3	16	V
3.3V	-0.3	3.4	V
	-0.3	3.4	V
ADC0	-	1.2	V
ADC1	-	1.2	V
5V	-	2	A

7.2

12

TypeC		4.5	5.0	5.25	V
DC		4.5	12	16	V
I	LTE	-	1.5	2	A

7.3

13 ESD

5V GND	± 8	± 10	KV
USB	± 8	± 10	KV
	± 8	± 15	KV
SIM	± 8	± 10	KV
	± 8	± 10	KV

7.4

14

参数	最小值	典型值	最大值	单位
正常工作温度范围 ⁴	-35	+25	+75	°C
扩展工作温度范围 ⁵	-40	-	+85	°C
存储温度范围	-40	-	+90	°C

8

8.1



12 EVB

8.2

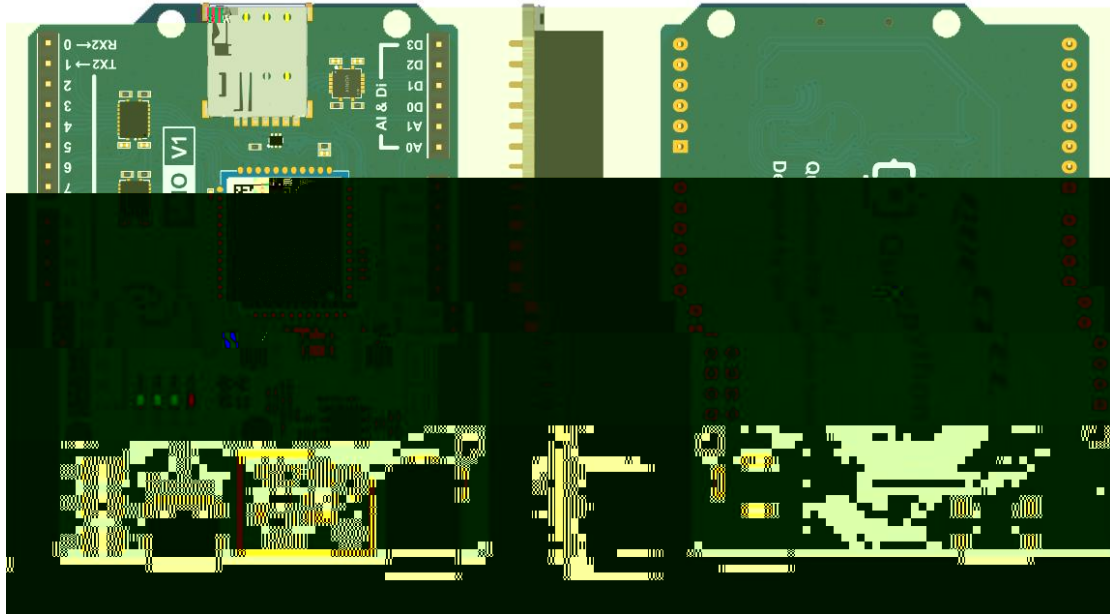

13 EVB

9

- 1
- 2

10 EVB

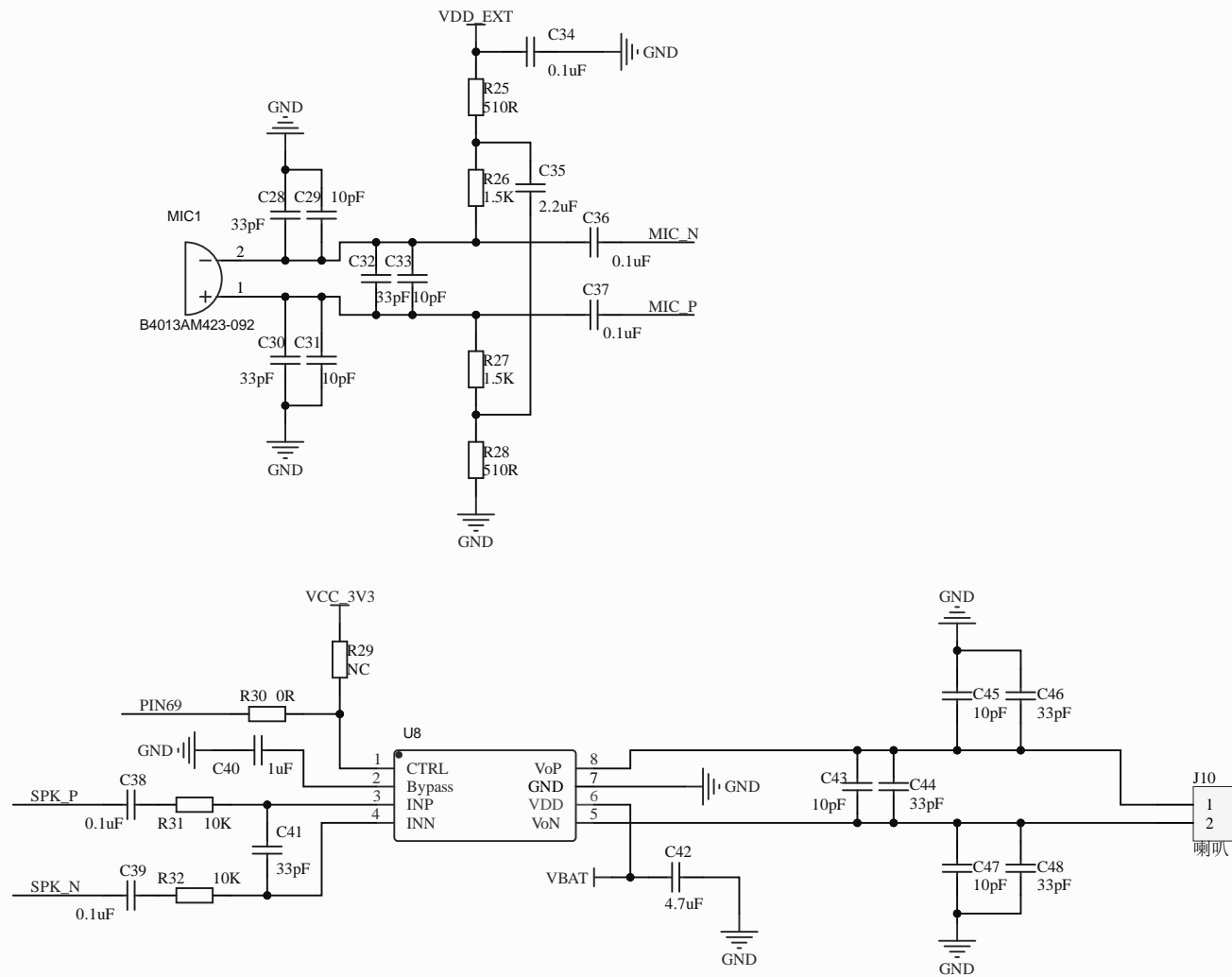

AUDIO

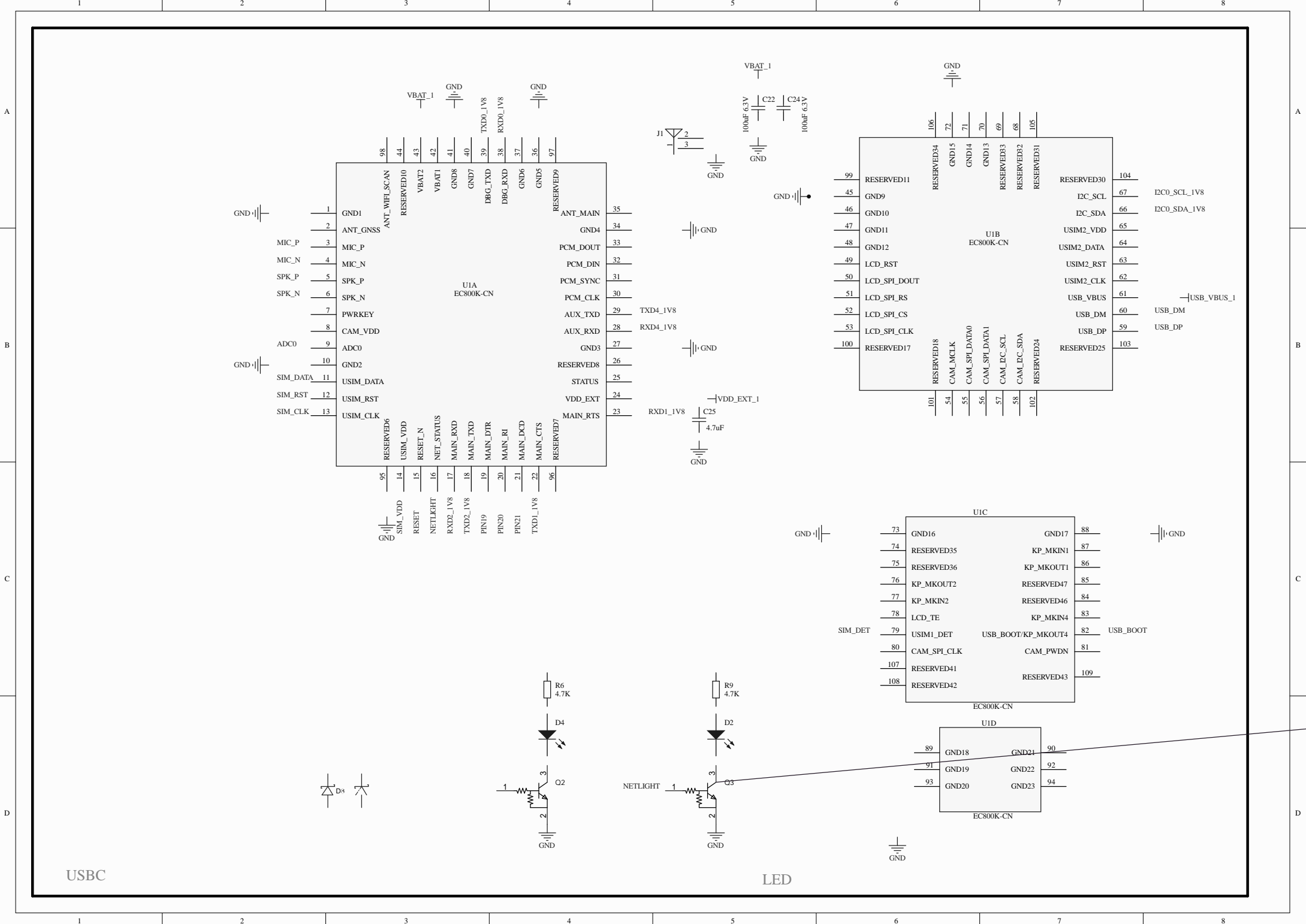

USBC

LED

A

B

C

D

A

B

C

D

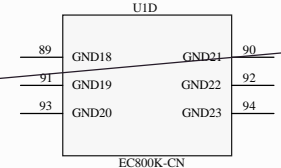
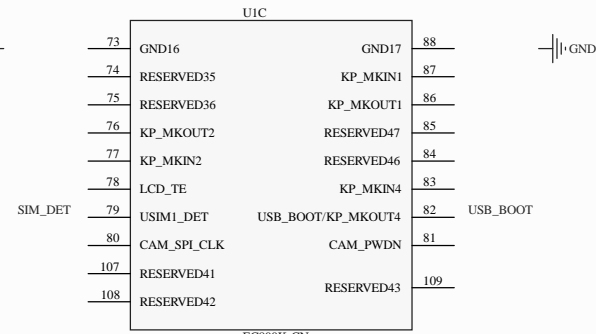
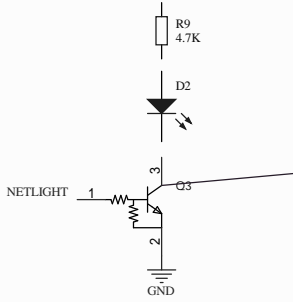
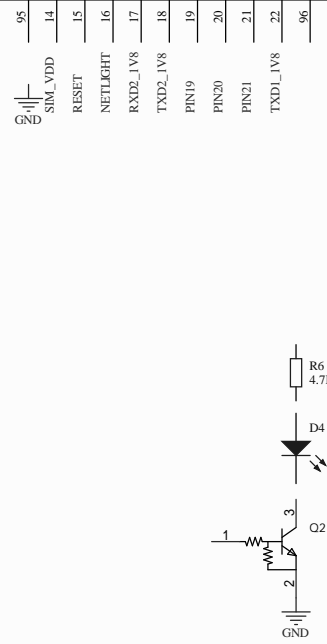
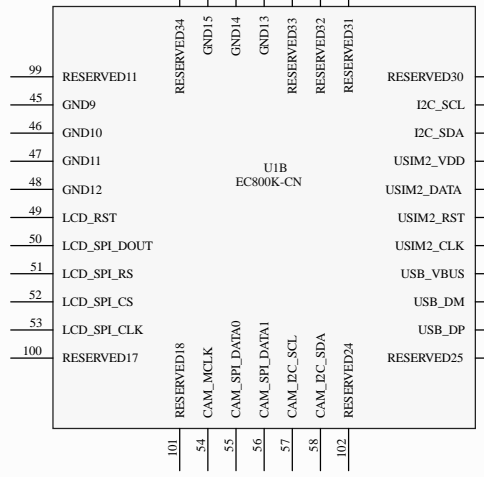
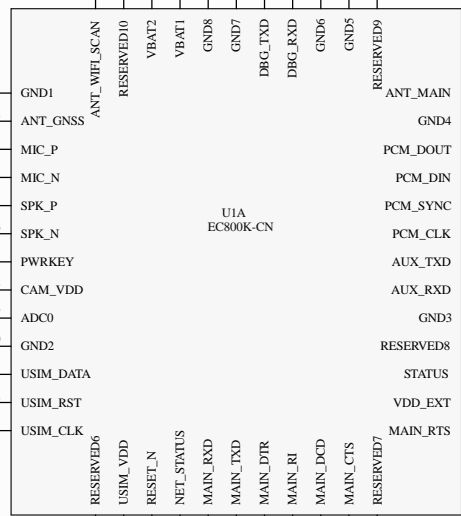

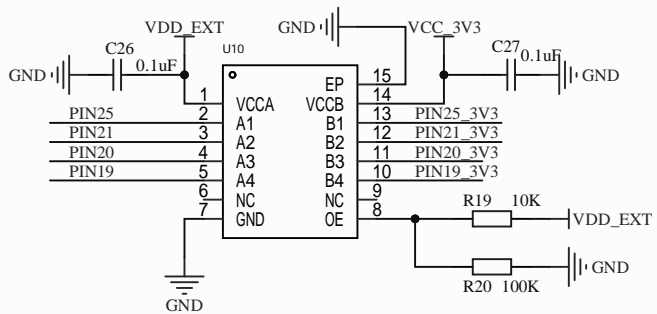
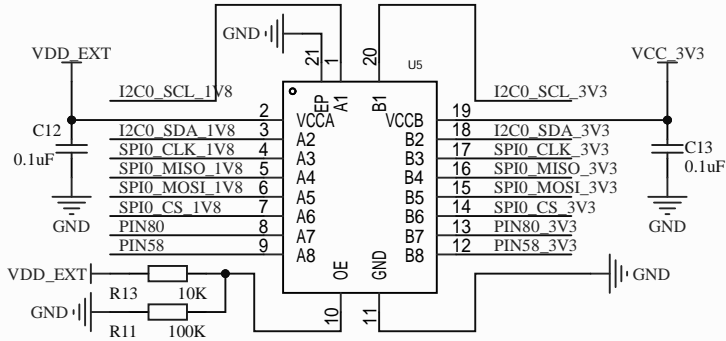
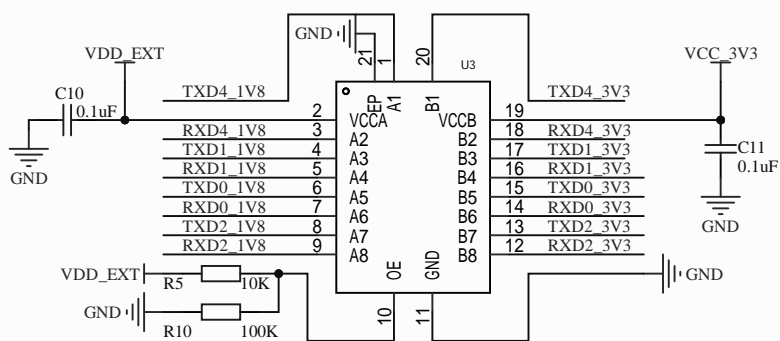

电平转换

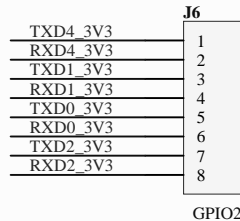
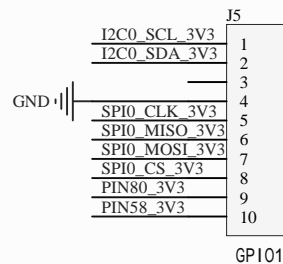
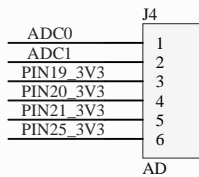
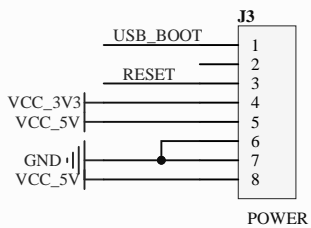

按键和排母

1

2

3

4

A

A

B

B

C

C

D

D

1

2

3

4

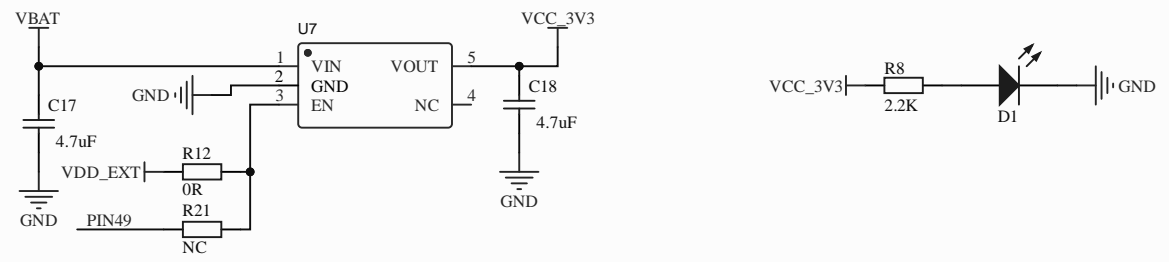

LDO

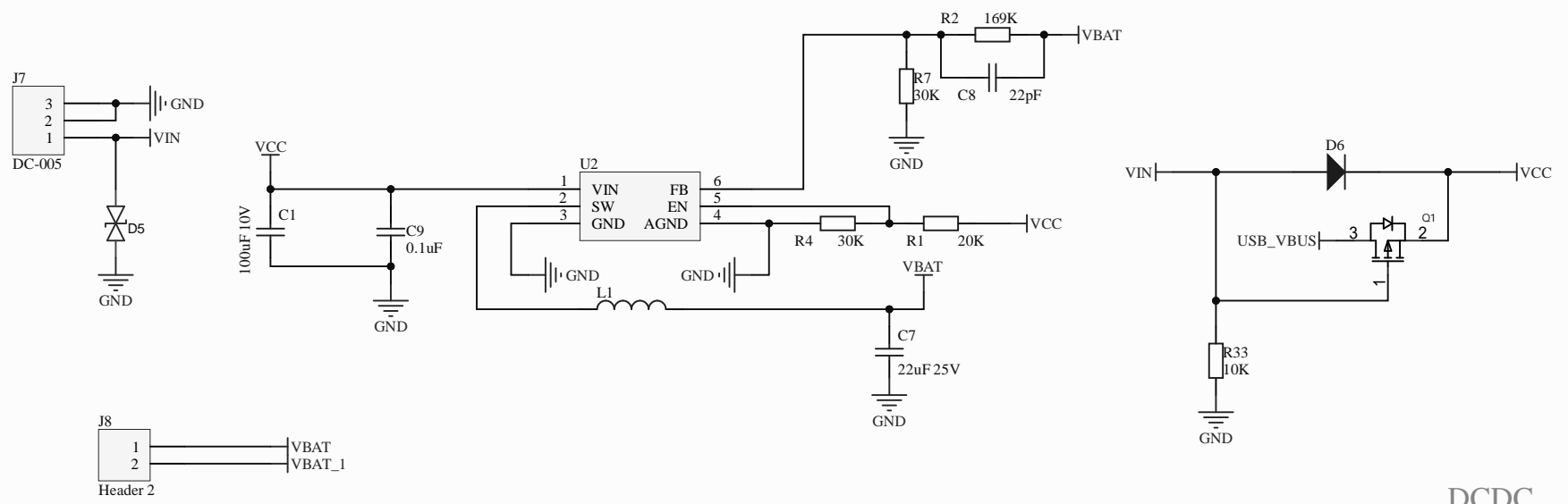

DCDC

1

2

3

4

5

6

A

A

B

B

C

C

D

D

SIM_VDD
 SIM_RST
 SIM_CLK
 SIM_DATA

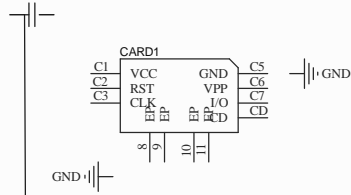
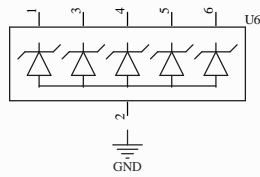

USIM

1

2

3

4

5

6